

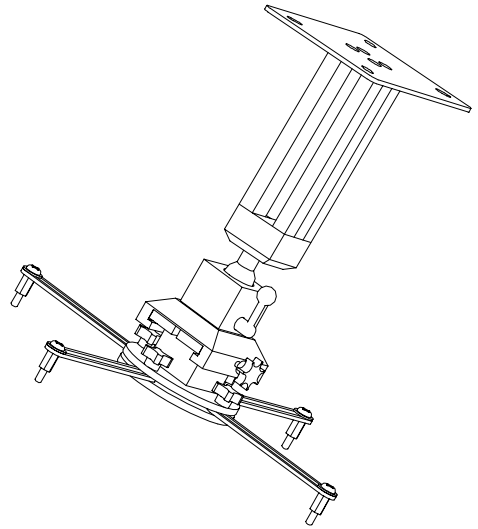

BRETTFORD

TC171LLA

Basic Flush Ceiling Mount with Quick Release Assembly Instructions



WARNING: This arm mount is intended to support projectors with a maximum weight of 26 lbs. If your projector does not have mounting nuts embedded in the bottom, it cannot be attached to this arm mount. **THIS ARM MOUNT IS INTENDED AS A CEILING MOUNT ONLY. A QUALIFIED PROFESSIONAL SHOULD BE USED TO PROPERLY INSTALL THIS UNIT TO THE CEILING. BRETTFORD DOES NOT RECOMMEND THE USE OF POWER TOOLS AND WILL NOT BE LIABLE FOR THE IMPROPER USE OR INSTALLATION OF ITS PRODUCTS.**

PARTS LIST

Qty	Description
1	Arm Assembly with Ceiling Plate
1	Mounting Bracket Head
1	Pressure Plate w/ 4 Countersunk Boreholes
1	Pressure Plate
4	Swivel Arms

HARDWARE LIST

Qty	Description
4	Countersunk Phillips Screws
4	Clamping Screws
1 Pkg.	M3 Distance Bolts with Screws & Washers
1 Pkg.	M4 Distance Bolts with Screws & Washers
1 Pkg.	M5 Distance Bolts with Screws & Washers
1 Pkg.	M6 Distance Bolts with Screws & Washers
4	Countersunk Phillips Bolts (These bolts can be used to replace the clamping screws for security)
2	Allen Wrenches

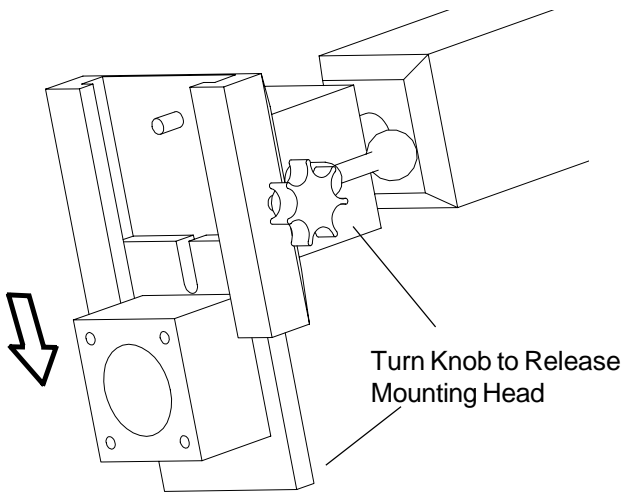

FIGURE 1

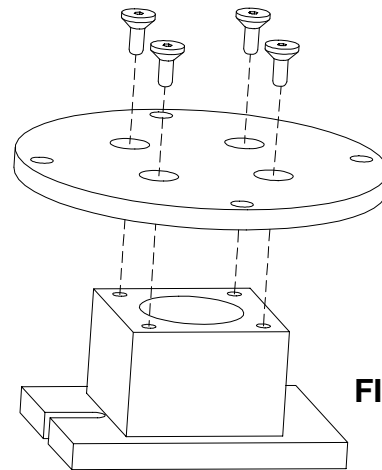
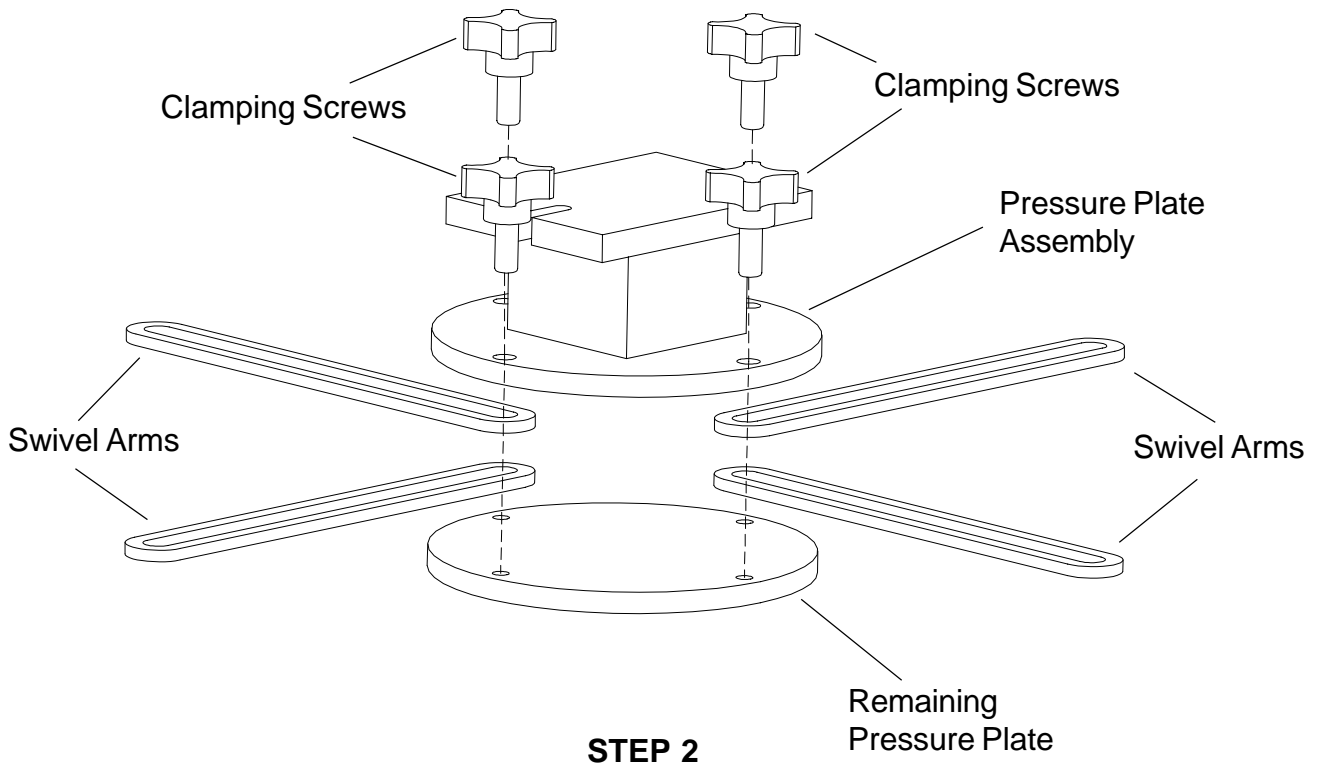

FIGURE 2

STEP 1

Remove the mounting bracket head from the arm assembly by unscrewing the knob as shown in **FIGURE 1**. Position the pressure plate (the one with the countersunk boreholes) onto the mounting bracket head. Using supplied Allen wrench secure together with the countersunk screws as shown in **FIGURE 2**.



Align pressure plate assembly, swivel arms and remaining pressure plate as shown. Loosely tighten together using the clamping screws. The number of arms you attach (either 3 or 4) will be determined by the number of mounting nuts embedded in the bottom of your projector. Lay your projector on its top (protected by a soft cloth or other suitable protection) to expose the bottom and the embedded mounting nuts.

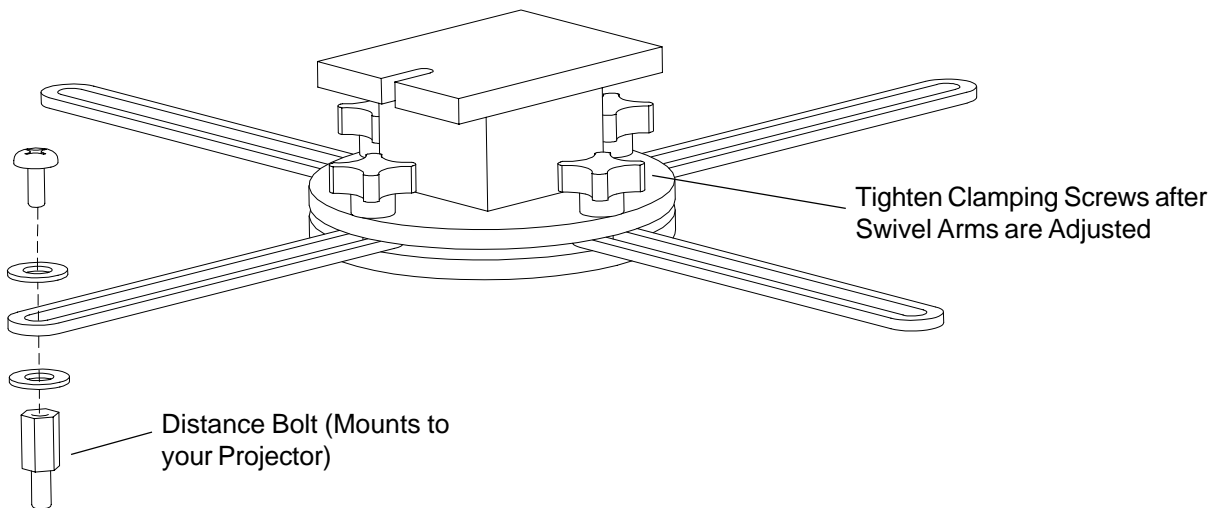

Select correct size distance bolts for your projector and align hardware as shown. Use the same hardware on all swivel arms. Swivel arms may be adjusted based on the size of the projector and the configuration of the embedded mounting nuts. Tightly secure clamping screws once swivel arms are in place. **NOTE:** The distance bolt mounts into your projector.

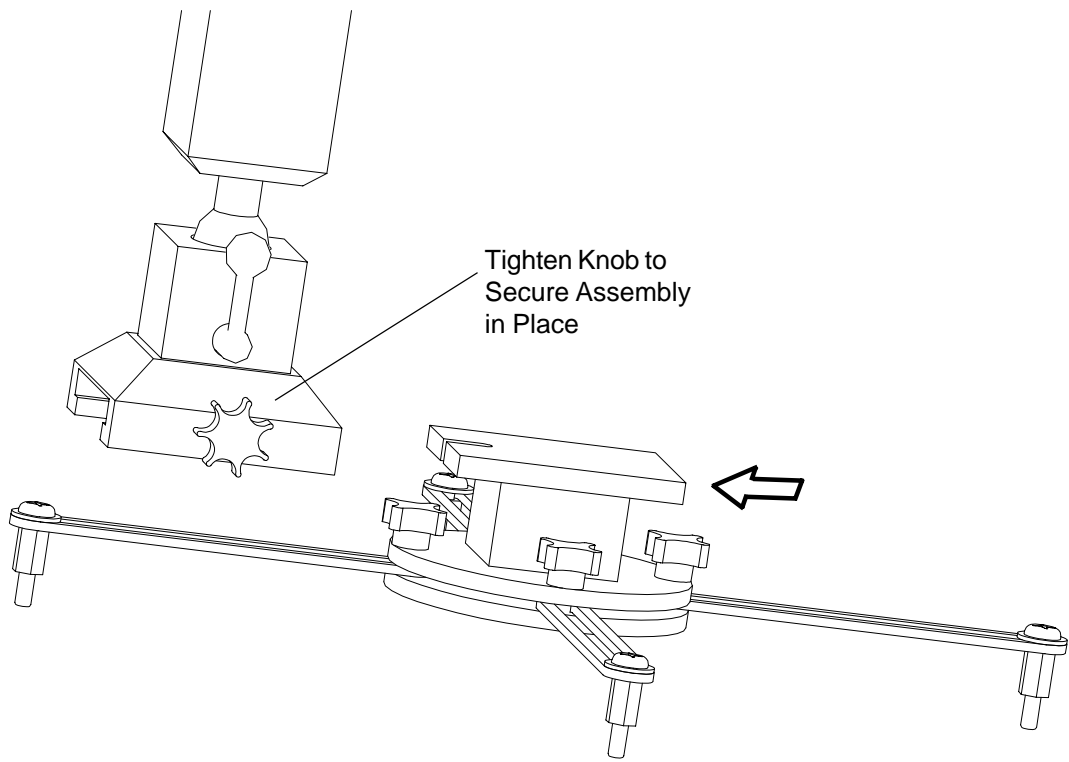

STEP 4

Slide the entire assembly (including projector) into the bottom of the arm assembly as shown. Turn knob tightly to secure in place.

ARM SWIVEL

NEVER MAKE ANY HANDLE ADJUSTMENTS WHEN CLAMPING IS TIGHTENED

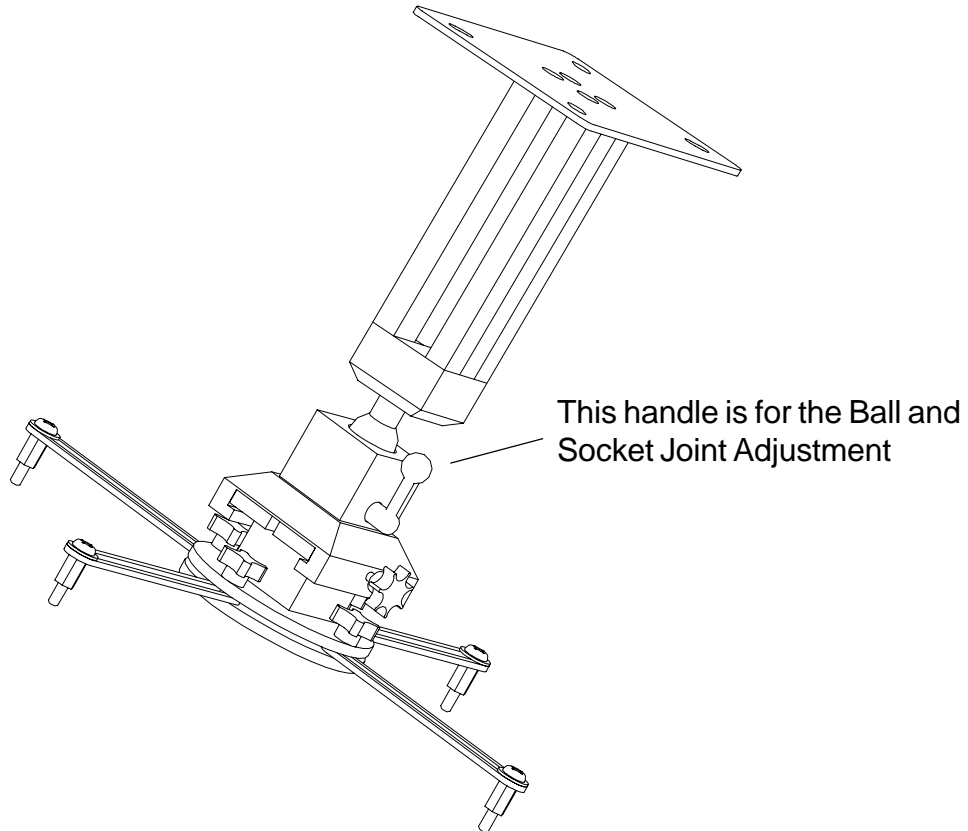

Bretford
11000 Seymour Avenue
Franklin Park, IL 60131
TEL: 847.678.2545
800.521.9614
FAX: 847.678.0852
800.343.1779

Bretford Ltd.
Technology House
2 Etongate, 110 Windsor Road
Slough, Berkshire SL1 2JA England
TEL: 01753 53 99 55
FAX: 01753 53 94 78

www.bretford.com

Part# 031-6646
Rev.01.14.04 CH